

Eddy Current Workshop (3)

Bath Plate with 2 Holes

1. General Description of Problem

The geometry of the problem is shown in Fig 1a and 1b. It consists a conducting ladder, having 2 holes, with a current carrying coil above. The coil can have 2 positions, as indicated in Fig 1b. The problem is to calculate the fields and eddy currents flowing around the limbs of the ladder.

2a. Specific Mesh Description

The problem has symmetry about a centre line, so only half of the 3-D space needs be discretised. The mesh defined does not include any meshing of the current carrying coil. If this is required by a particular package, the mesh will have to be modified from that given here. However an attempt to keep to the general mesh structure is encouraged. (see section 2b)

Fig 1c shows the number of elements to use in the region enclosing the conducting ladder. The first row of elements outside the ladder are used to grade the mesh to a uniform distribution in the x and y directions. The equal spacing is then continued to the outer boundary. The distance of the successive annuli are shown in Fig 2. The spacing in the z direction is shown in Fig 3, including the region where the coil would lie (although it is not specifically meshed)

2b. User Defined Mesh

If, for example, the coil needs to be meshed in the users package, this may be done, but an attempt must be made to keep to the same number of elements if possible. Adaptive mesh generators may also be used here.

3. Boundary Conditions

The driving field originates in the coil, carrying a current equivalent to 1260 Amp turns. Two positions of coil are to be solved, the positions shown in Fig 1b. On the outermost boundary, away from the conducting ladder, a condition of $B(\text{normal})=0$ is to be imposed.

4. Presentation of Results

Solutions along the centre line of the geometry are to be obtained (shown as line AB in Fig 1b, lying 0.5mm above the top surface of the conducting ladder). The following

are to be calculated.

The magnitude (in mT) and phase (degrees) of z directed field (B) along the line AB, with the driving coil at the two positions shown in Fig 1b, for the two frequencies 50Hz and 200Hz.

Global quantities to be calculated are the total flux flowing through the two holes in the ladder, and the total current flowing through the central limb.

Problem 3
Bath Plate with Two Holes

10 turn search coils

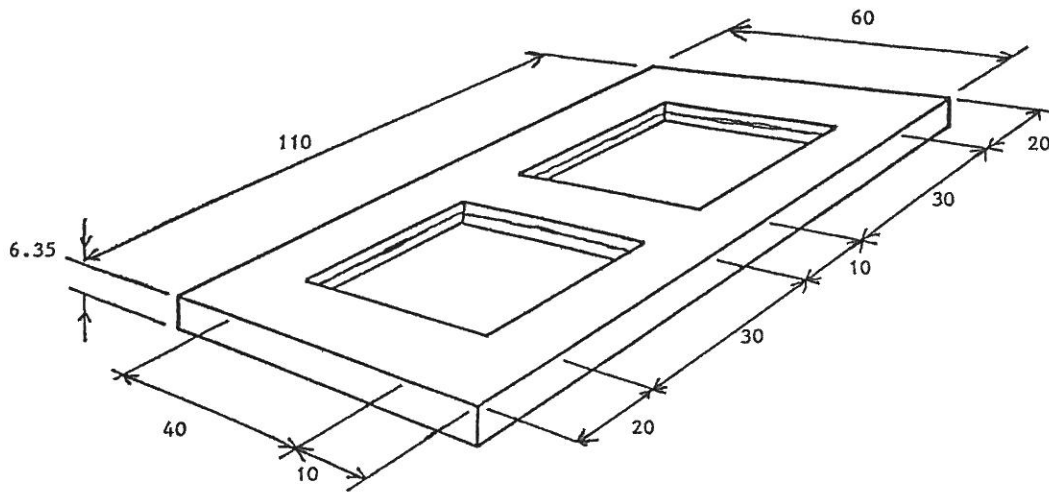

$$\sigma = 0.3278 \times 10^8$$

dimensions mm

Figure 1a.

Conducting Ladder Test Problem

Coil 1260 Amp turns

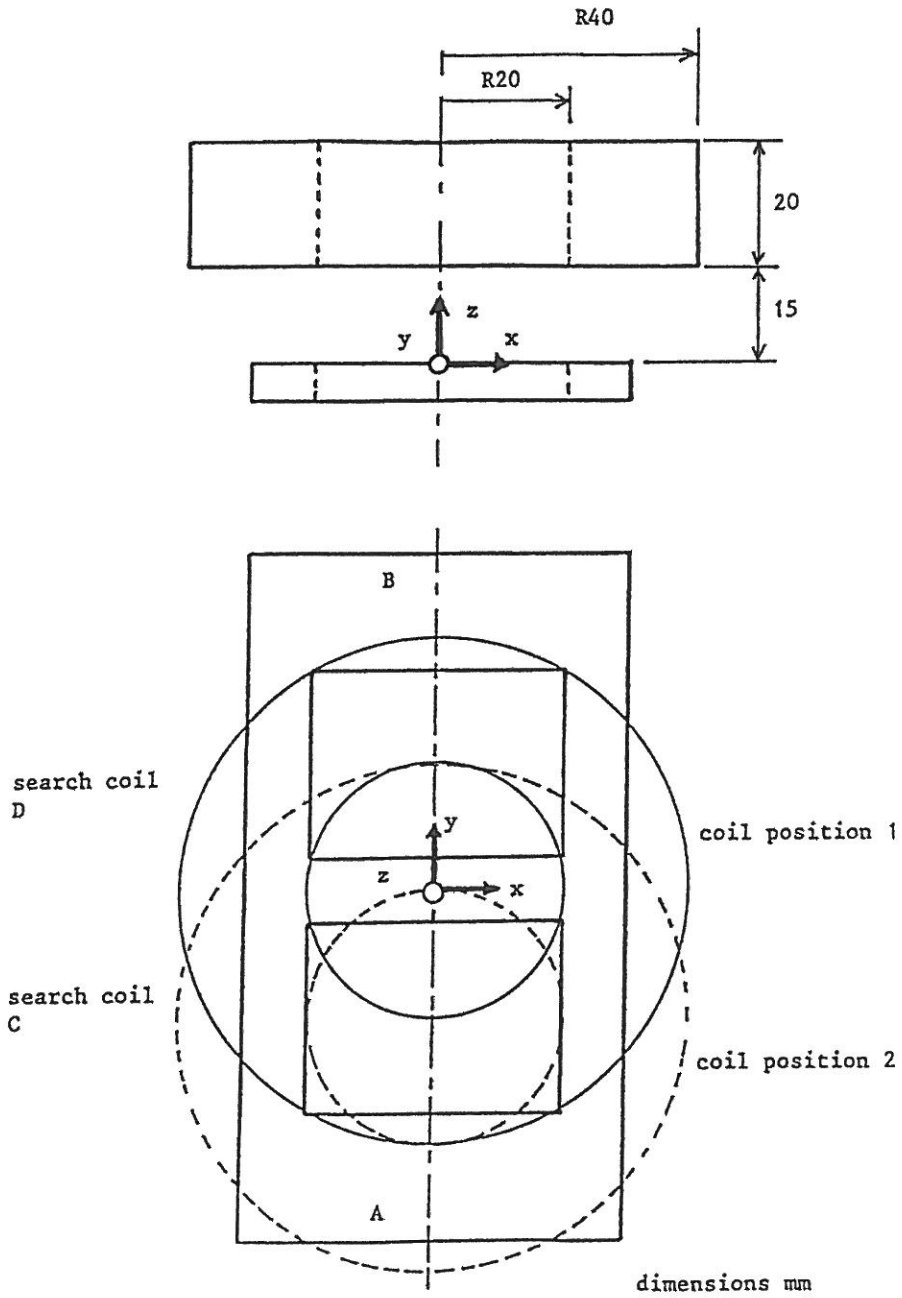

line A-B from (0, -55, 0.5) mm to (0, 55, 0.5) mm

Figure 1b.

The Conducting Ladder and the Two Excitation Coil Positions

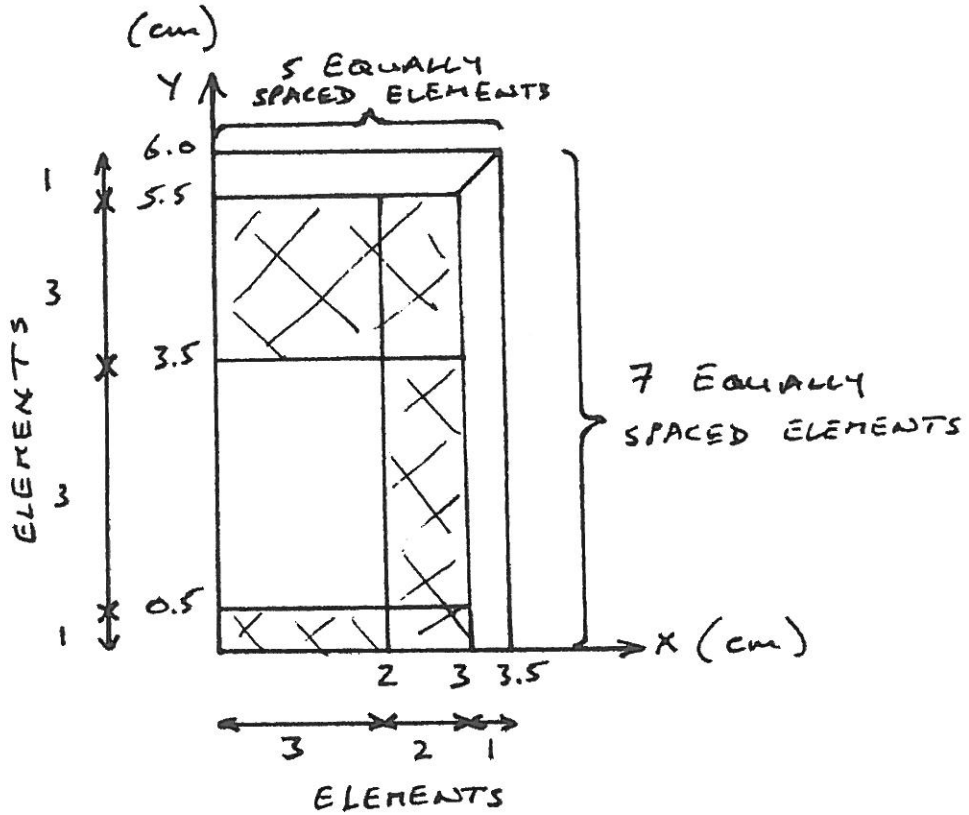

QUARTER OF PROBLEM IN X-Y PLANE
(SHADED AREA IS PLATE)

Figure 1c.

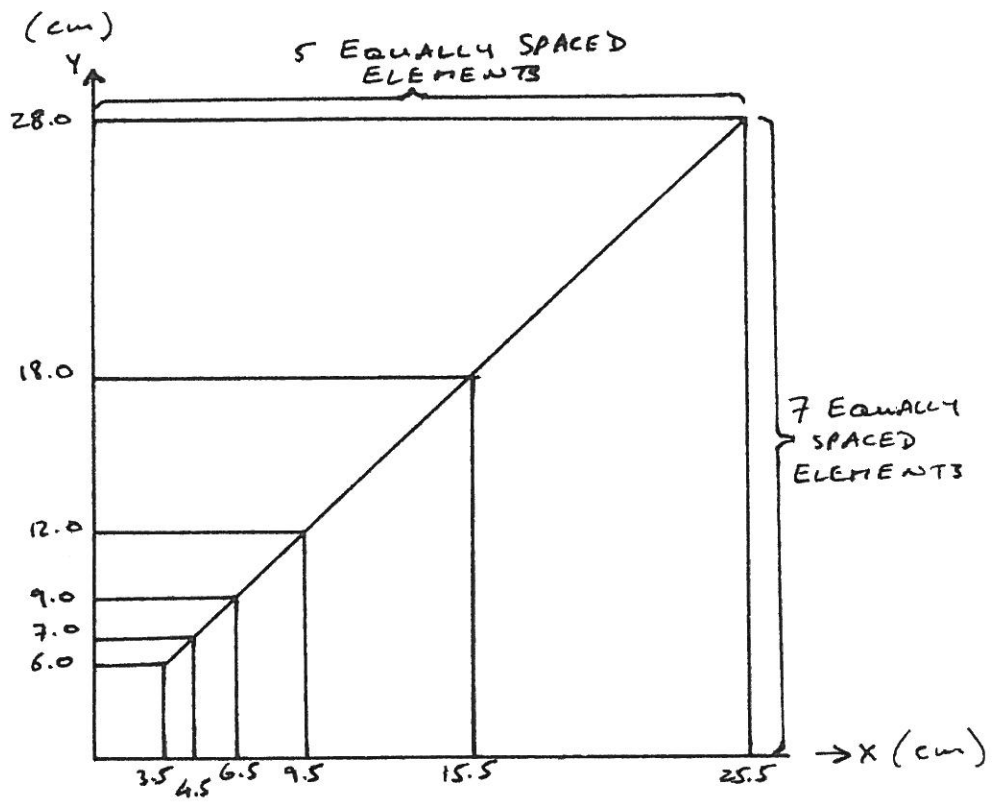
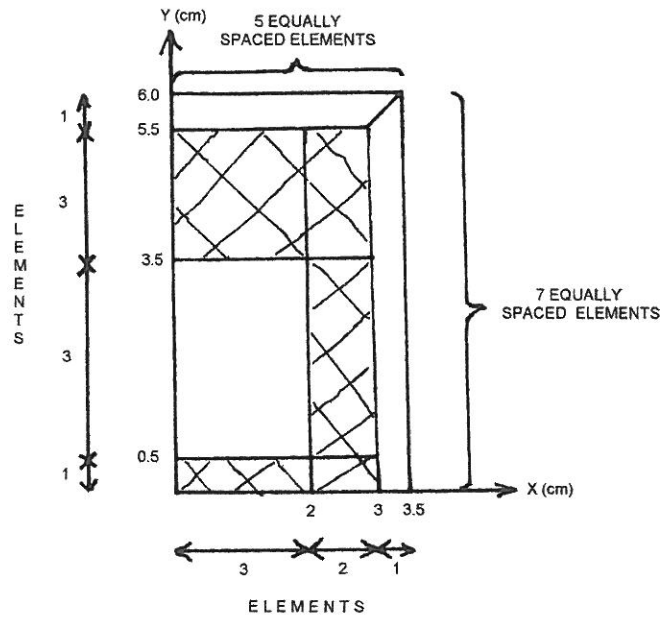

Figure 2

The Conducting Ladder and the Two Excitation Coil Positions



Quarter of Problem in X-Y plane (shaded area is plate)

Figure 1c.

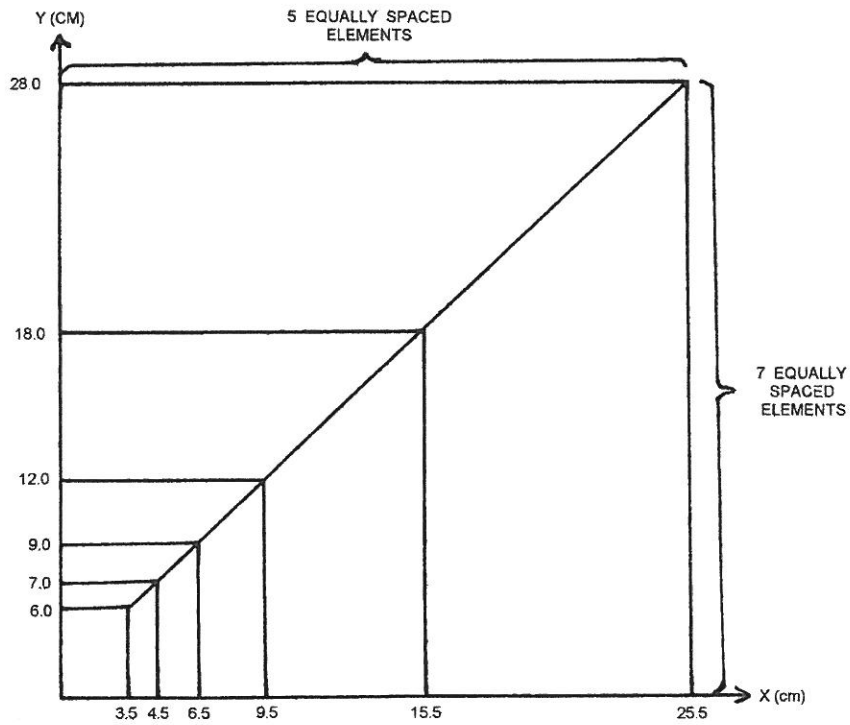
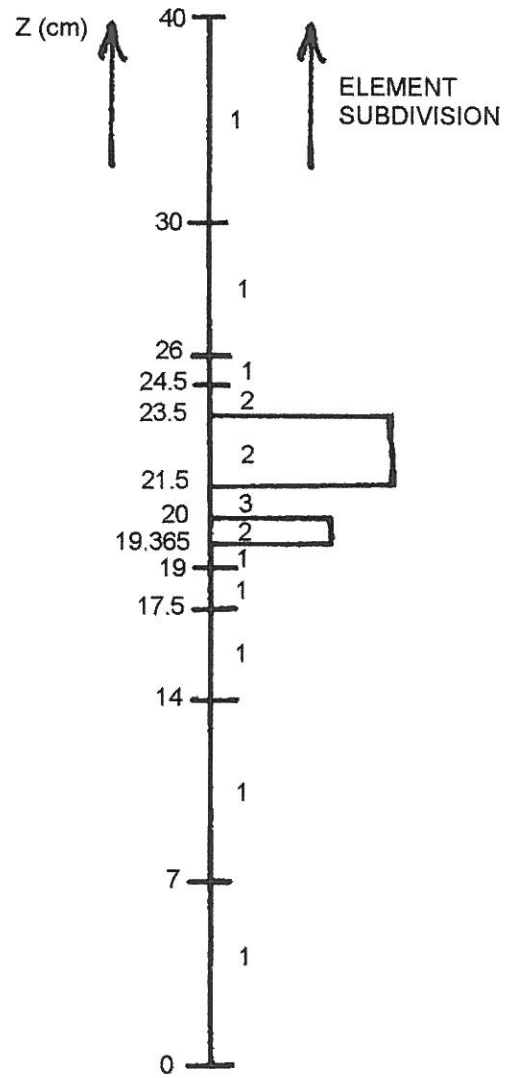

Figure 2



Vertical (Z) Discretisation

Figure 3