

Development of Axial Gap Generators for Microhydro System utilizing Magnetic Material Attached Magnetic Flux Concentrated Permanent Magnets

Katsuyuki Shiota, Takashi Todaka and Masato Enokizono

Department of Electrical and Electronic Engineering, Faculty of Engineering, Oita University
700 Dannoharu, Oita, 870-1192, Japan
todaka@oita-u.ac.jp

Abstract— Purpose of this study is to develop a direct-drive, high-efficiency, small-sized axial gap microhydro-electric generator whose diameter is around 300 mm - 500 mm and output power is 1 kW at 20 rpm. In this designing, we have tried to use magnetic material attached magnetic flux concentrated permanent magnets (MFCPM) arrangement in order to feed larger magnetic flux. Also the magnetic flux is enhanced by inserting a piece of electrical steel sheets in the MFCPM arrangement. The structure of the MFCPM arrangement, the combination of the segmented permanent magnets and the electrical steel sheets is optimized in cut-and-try optimizations by using the three-dimensional finite element method. The calculated result is compared with that of the surface permanent magnet (SPM) type axial gap generator with a combination of 36 poles - 54 slots.

Index Terms—Axial-gap generators, permanent magnet machines, permanent magnet, finite element method, microhydro-electric generator

I. INTRODUCTION

Distributed generation is expected to become more important in the future generation system and the cost of small-scale power generation technology has been steadily dropping over a period of several years while the efficiency of energy conversion of various technologies has steadily been rising [1]. Advances have occurred in such areas as solar thermal energy conversion, wind energy, hydropower, fuel cell technology, and various types of small engines.

To more widespread small power systems, it is important to develop high-power, high-efficiency, small-sized and low-cost generators [2]. Permanent magnet generators (PMG) are in general small-sized and high-efficiency in comparison with the other generators. Because the PMGs don't require a power supply circuit to feed the magnetic flux and inspection, it is useful socially and economically. However, almost all of PMGs in commercially use are high revolution speed and need a speed-increasing gear for microhydro-electric systems and small-scale wind power generation systems. Therefore the total efficiency of such generation systems becomes low (around 30 - 40 %). On the other hand, axial-flux permanent magnet machines whose flat and compact structure are very adequate in many applications, have been widely used in the last few years [3]-[8]. Because direct-drive machines are also restricted its mounting space, axial-gap structure is desirable.

In this work, we have aimed to develop a direct-drive, high-efficiency, small-sized axial gap microhydro-electric generator whose diameter is around 300 mm - 500 mm. In the designing, we have tried to use magnetic material attached

magnetic flux concentrated permanent magnets (MFCPM) arrangement in order to feed larger magnetic flux [9]-[10]. The MFCPM arrangement consists of segmented permanent magnets and laminated core bars. The same magnetic poles of the segmented permanent magnets are faced to each other and the laminated core bar is sandwiched them to concentrate magnetic flux inside.

Because the targeted output power of the generation is 1 kW at 20 rpm in the limited volume, a multi-pole construction in combination of 36 poles - 54 slots is applied to designing. The construction of MFCPM is optimized by using the three-dimensional finite element method (3D FEM). The calculated results of the optimized model were compared with that of the surface permanent magnet (SPM) type model.

II. BASIC CONSTRUCTION AND ANALYZED MODEL

The static characteristic of the axial gap generator models having δ mm width laminated core bar at the inner diameter in MFCPM arrangement are analyzed with 3D FEM. Fig. 1 shows the double layer type dual axial gap generator full model with $\delta = 6$ mm. The outer and inner diameters of the model are 350 mm and 190 mm, respectively. The axial length was 249mm and the air gap length was assumed to be 1mm. As shown in Fig. 1, the model consists of the two stator-yokes (35A210) and the three rotor-yokes (35A210) mounting permanent magnets. The stator coils are the concentrated windings. The number of turns per phase was kept to be 1800 turns during the simulations.

Fig. 2 (a) shows the construction of MFCPM arrangement. The laminated core bar made of electrical steel sheets (50A1000) was sandwiched with the three permanent magnets. The thickness of the upper and lower magnet are $a = 6$ mm and $b = 6.5$ mm, respectively. The width and thickness of the laminated core bar made of electrical steel sheets on the cross-section at the inner diameter are δ mm and 6mm, respectively. The width of the laminated core bar, δ was changed from 1 mm to 12 mm per 1 mm step. In this construction, we can generate large air-gap flux with a small amount of permanent magnets. Fig. 2 (b) shows the construction of the SPM arrangement. The thickness of the magnet is 12.5 mm. The arrows of each arrangement show the magnetization direction. The permanent magnets of each arrangement are assumed as a NdFeB magnet and the residual magnetization of the permanent magnets was assumed to be 1.21 T.

III. ANALYZED RESULTS AND DISCUSSIONS

Figs. 3 and 4 show the waveforms and the effective values of the U-phase electromotive force (EMF). As expected, the model utilizing the MFCCPM arrangement excepting for the case at $\delta = 1$ mm showed larger EMF than that of the SPM type. The effective value of the EMF was highest when the $\delta = 10$ mm.

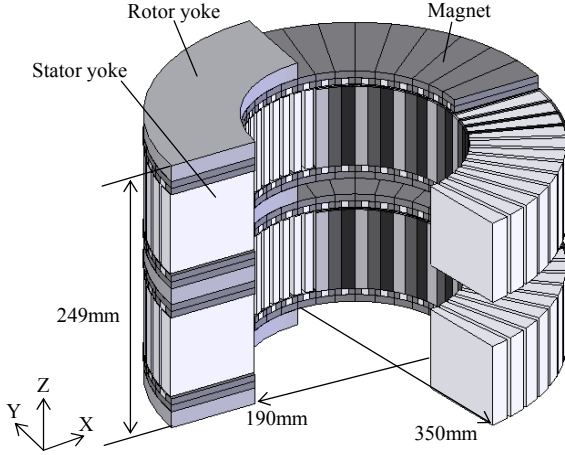

Fig. 1. Structure of the full model with $\delta = 6$ mm.

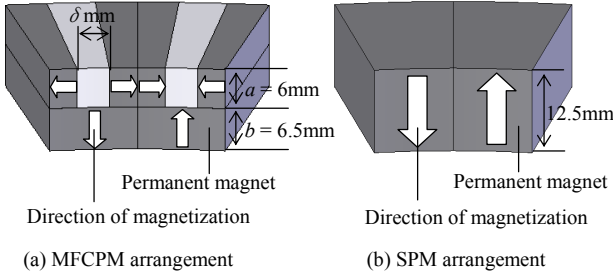

Fig. 2. Arrangement of magnets.

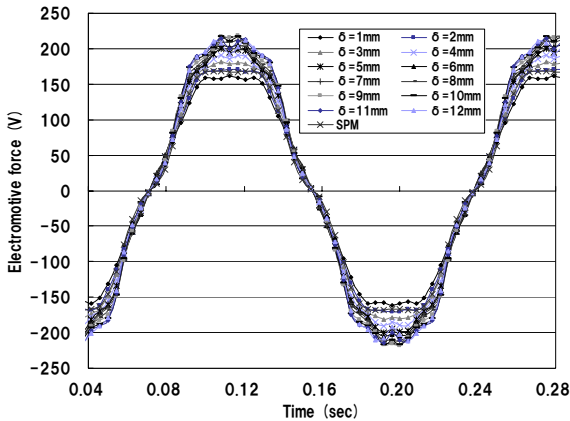

Fig. 3. Waveforms of the EMF in U-phase winding.

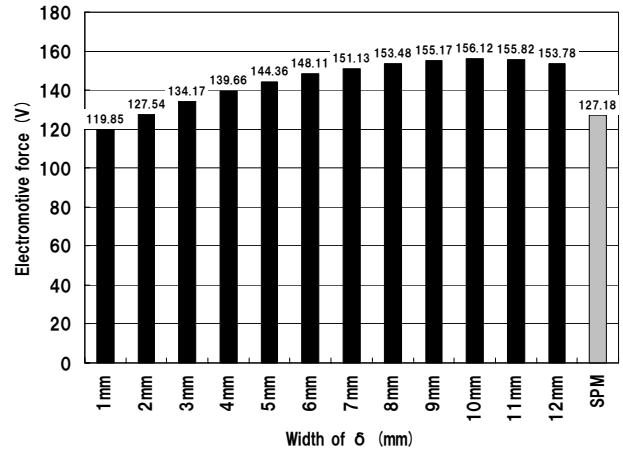

Fig. 4. Comparison of the effective values of EMF in U-phase winding.

IV. CONCLUSION

Usefulness of the MFCCPM arrangement to generate higher magnetic flux density in the air-gap and reduce size of machines was confirmed in the results as shown in this paper. More detailed results will be shown in the full paper.

REFERENCES

- [1] T. Ackermann, G. Andersson, L. Solder, "Distributed generation: a definition," *Electric Power Systems Research*, vol.57, pp. 195-204, 2001.
- [2] A. Ikariga, H. Shimoji, T. Todaka, M. Enokizono, "High-density permanent magnet machines," *Proc. of ISEM*, vol. 12, pp. 112-113, 2005.
- [3] C. C. Chan, "Axial-field electrical machines-Design and applications," *IEEE Trans. Energy Convers.*, vol. EC-2, no. 2, pp. 294-300, 1987.
- [4] J. Azzouzi, G. Barakat, B. Dakyo, "Quasi-3-D Analytical Modeling of the Magnetic Field of an Axial Flux Permanent-Magnet Synchronous Machine," *IEEE Trans. Energy Convers.*, vol. 20, no. 4, pp. 746-752, 2005.
- [5] K. J. Meessen, J. J. H. Paulides, E. A. Lomonova, "Analysis of 3-D effects in segmented cylindrical quasi-Halbach magnet arrays," *IEEE Trans. Magn.*, vol. 47, no. 4, pp. 727-730, 2011.
- [6] P. Virtic, P. Pisek, M. Hadziselimovic, T. Marcic, B. Stumberger, "Torque Analysis of an Axial Flux Permanent Magnet Synchronous Machine by Using Analytical Magnetic Field Calculation," *IEEE Trans. Magn.*, vol. 45, no. 3, pp. 1036-1039, 2010.
- [7] T. F. Chan et al, "An axial-flux permanent-magnet synchronous generator for a direct-coupled wind-turbine system," *IEEE Trans. Energy Convers.*, vol. 22, no. 1, pp. 86-94, 2007.
- [8] S. Javadi, M. Mirsalim, "A coreless axial-flux permanent-magnet generator for automotive applications," *IEEE Trans. Magn.*, vol. 44, no. 12, pp. 4591-4598, 2008.
- [9] M. Enokizono, H. Shimoji, T. Todaka, Y. Tsuchida, A. Ikariga, S. Shimoji, Y. Goto, M. Obata, Y. Kido, "Development of high density and high efficiency machines," *Journal of Materials Processing Technology*, vol. 181, no. 1-3, pp. 110-114, 2007.
- [10] K. Eguchi, T. Todaka, M. Enokizono, "Examination of magnet structure of magnetic flux concentrating type surface magnet motors," *Proc. of the 12th Japan-Korea Joint Symposium on the Applied Electromagnetics*, vol. 12, pp. 35-36, 2009.